

LOW LOADER



CONVENTIONAL



SL2

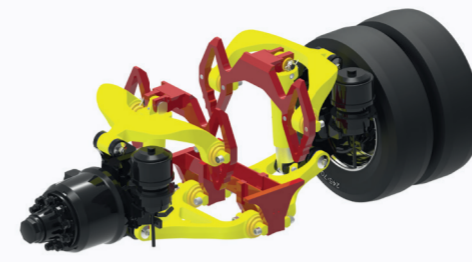

PL2

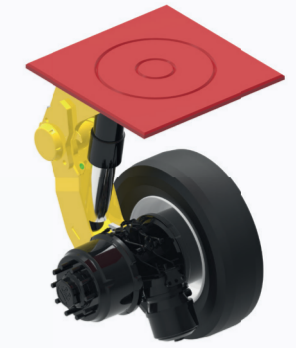

HEIGHT DIFFERENCE (deck height 300 mm)



600 mm



550 mm

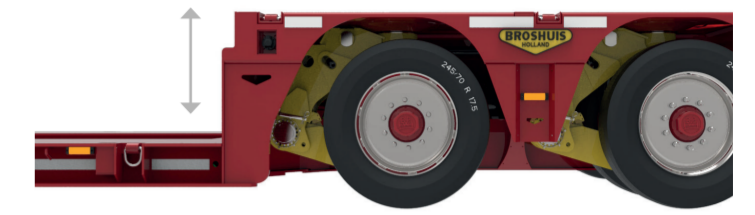

570 mm

TRAVEL

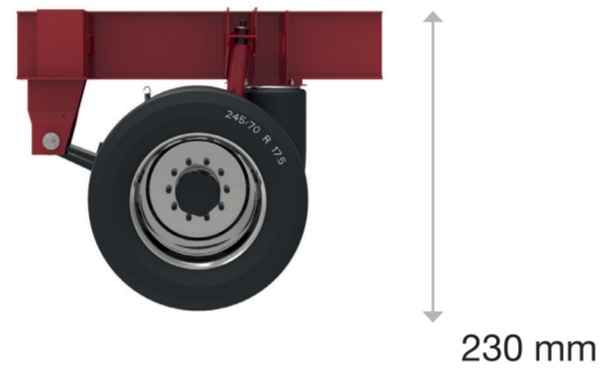

230 mm

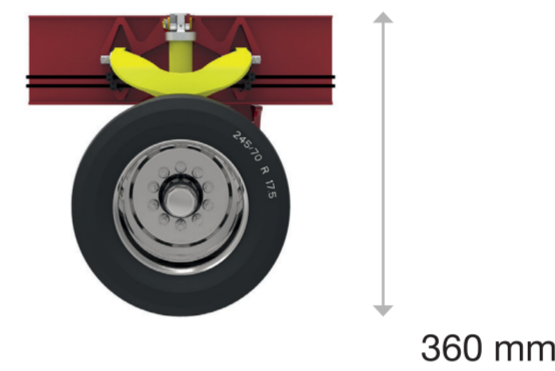

360 mm

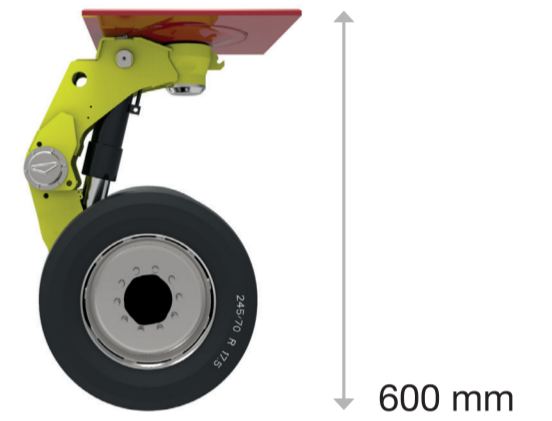

600 mm

MAX. STEERING ANGLE

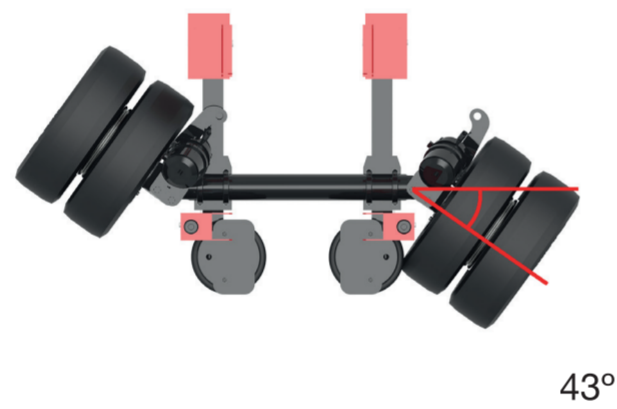

43°



59°



70°

CAPACITY TECHNICAL

12 T

14 T

14 T

DUTCH PERMITS

10 T

10 T

12 T

GERMAN PERMITS

10 T

12 T

12 T

STABILITY

++

+++

+

ALIGNMENT EFFECTED BY DRIVING HEIGHT

Effected

No effect

No effect

TYRE EXCHANGE

Easy

Easy

Hard

MAINTENANCE COST

Low

Low/Medium

Medium



SAFETY



QUALITY



INNOVATION

SEMI LOW LOADER



CONVENTIONAL

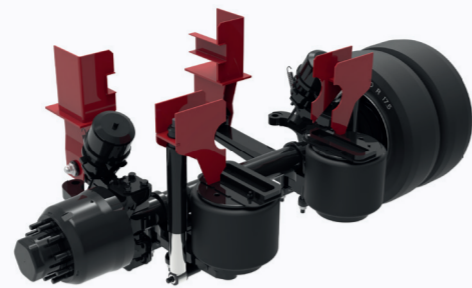

SL2

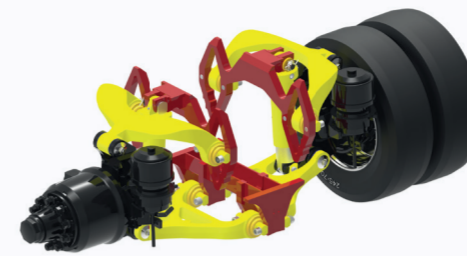

PL2

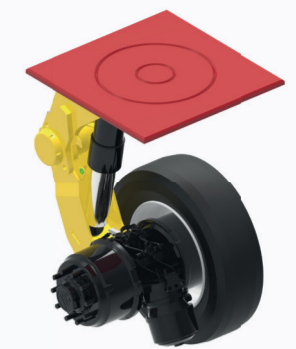

DRIVING HEIGHT MIN.

GROUND CLEARANCE MIN. (under spine)



Height depending on number of axles

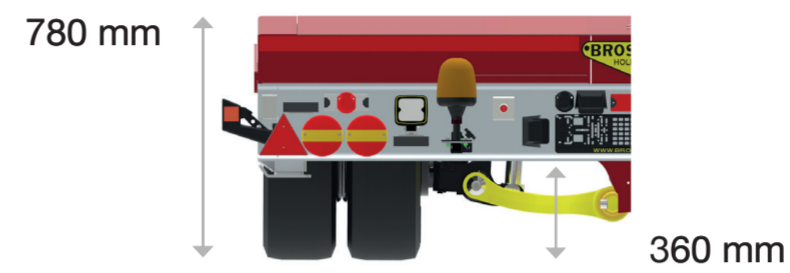

DRIVING HEIGHT MAX.

GROUND CLEARANCE MAX. (under spine)



Height depending on number of axles

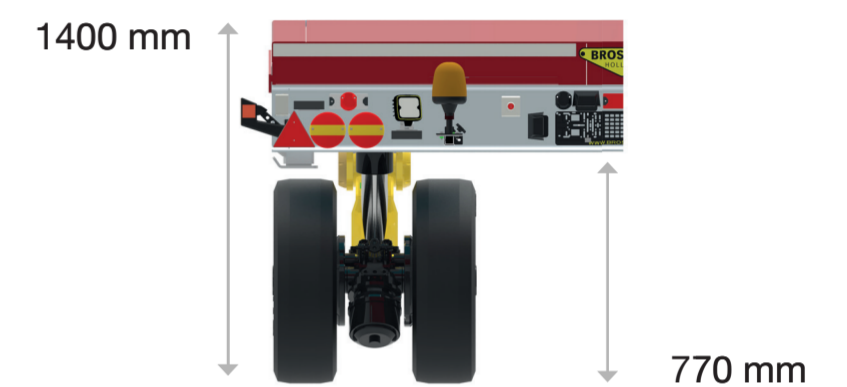
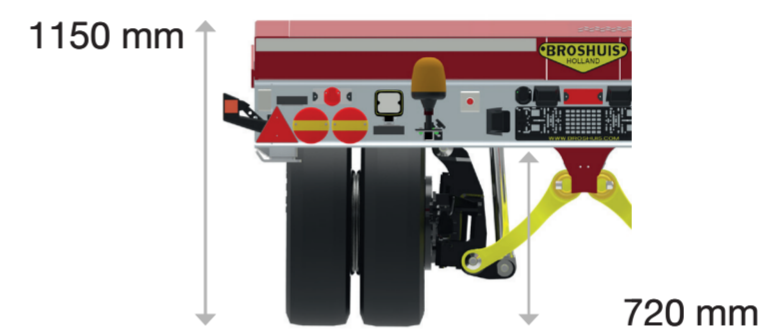

MAX. STEERING ANGLE

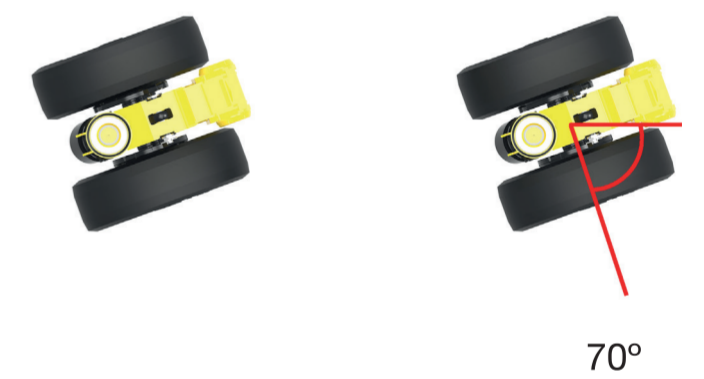
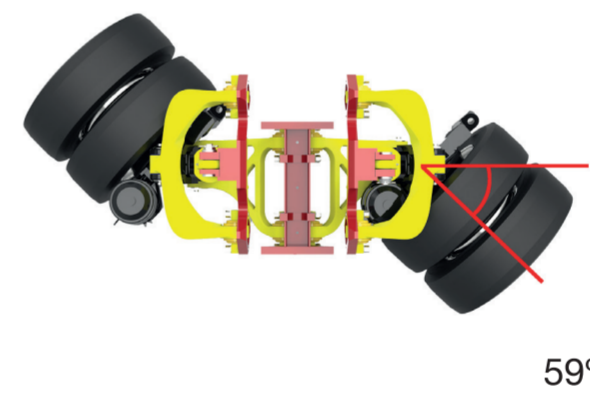
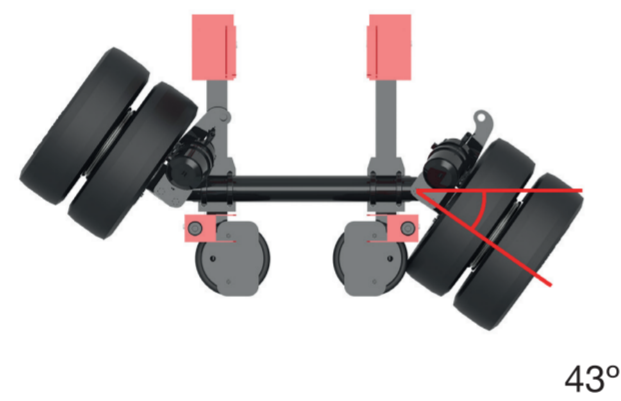

CAPACITY TECHNICAL

12 T

14 T

14 T

DUTCH PERMITS

10 T

10 T

12 T

GERMAN PERMITS

10 T

12 T

12 T

STABILITY

++

+++

+

ALIGNMENT EFFECTED BY DRIVING HEIGHT

Effectuated

No effect

No effect

TYRE EXCHANGE

Easy

Easy

Hard

MAINTENANCE COST

Low

Low/Medium

Medium

